

NOTE: SEWER MAINS SHALL BE INSULATED WITH A MINIMUM OF 2" URETHANE. SEWER SERVICES SHALL BE INSULATED WITH A MINIMUM 3" OF URETHANE

A TYPICAL PIPE CONNECTIONS
NOT TO SCALE

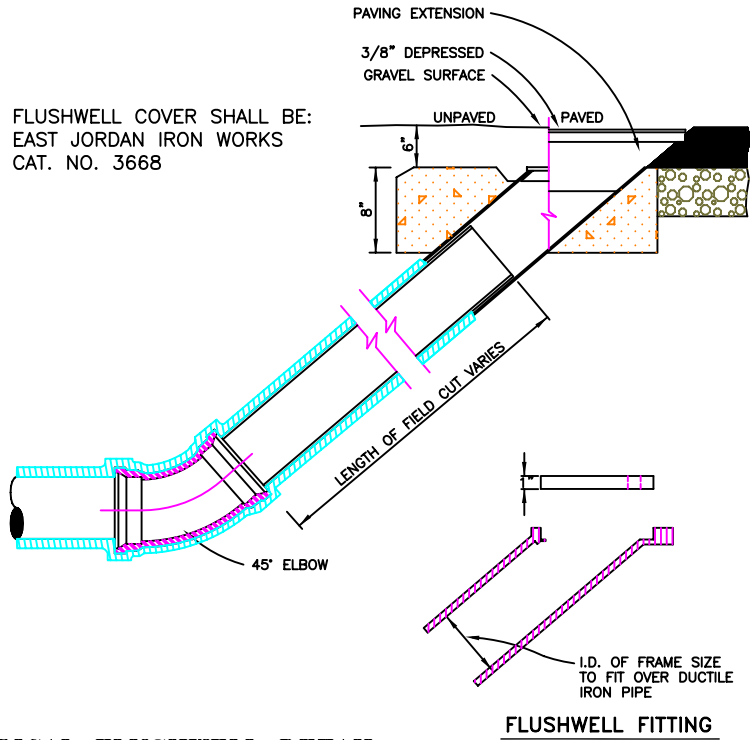

C TYPICAL FLUSHWELL DETAIL
NOT TO SCALE

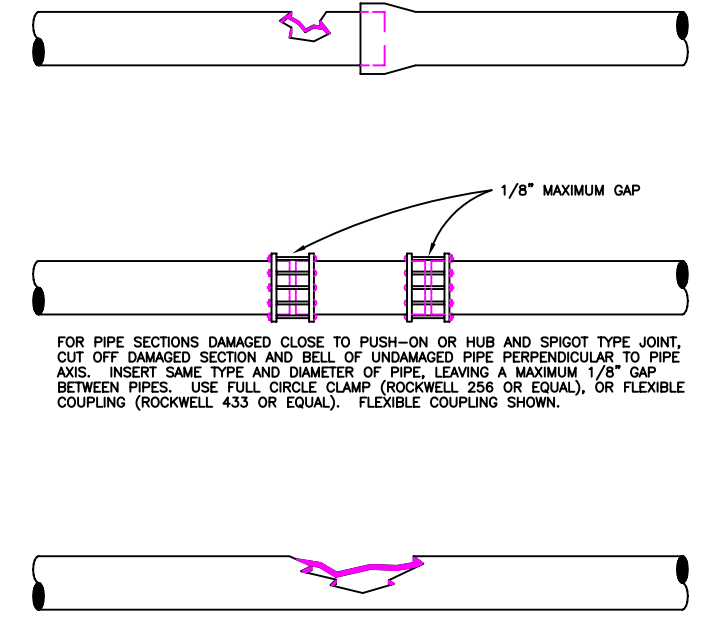

FOR PIPE SECTIONS DAMAGED CLOSE TO PUSH-ON OR HUB AND SPIGOT TYPE JOINT, CUT OFF DAMAGED SECTION AND BELL OF UNDAAGED PIPE PERPENDICULAR TO PIPE AXIS. INSERT SAME TYPE AND DIAMETER OF PIPE, LEAVING A MAXIMUM 1/8" GAP BETWEEN PIPES. USE FULL CIRCLE CLAMP (ROCKWELL 256 OR EQUAL), OR FLEXIBLE COUPLING (ROCKWELL 433 OR EQUAL). FLEXIBLE COUPLING SHOWN.

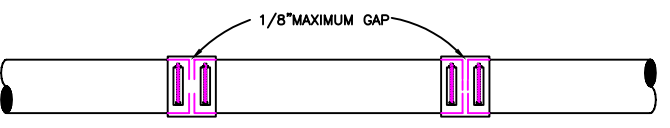

FOR PIPE DAMAGED NEAR THE MIDDLE OF THE SECTION, REMOVE THE DAMAGED SECTION, MAKING CUTS PERPENDICULAR TO THE PIPE AXIS. INSERT SAME TYPE AND DIAMETER OF PIPE, LEAVING A MAXIMUM GAP BETWEEN PIPES OF 1/8". USE FULL CIRCLE CLAMP (ROCKWELL 256 OR EQUAL), OR FLEXIBLE COUPLING (ROCKWELL 433 OR EQUAL). FULL CIRCLE CLAMP SHOWN.

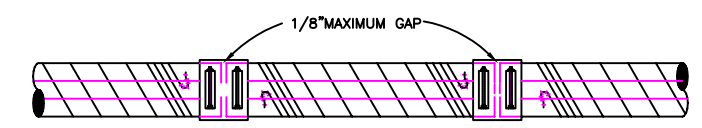

WHEN REPAIRING WOOD STAVE PIPE, CUT AND REMOVE THE DAMAGED SECTION, MAKING CUTS PERPENDICULAR TO THE PIPE AXIS. STAPLE BANDING TO ALLOW A MINIMUM OF THREE WRAPS OF THE WIRE AT EACH END. STAPLE ACCORDING TO DETAIL THIS SHEET. CUT NEW WSP TO LENGTH, ALLOWING A MAXIMUM OF 1/8" GAP AT EACH END. CREOSOTE SHALL BE APPLIED TO ALL FRESHLY CUT ENDS OF PIPE. INSTALL FLEXIBLE COUPLING (ROCKWELL 413 OR EQUAL), FULL CIRCLE CLAMP (ROCKWELL 256 OR EQUAL). OR LOCALLY FABRICATED BAND AS SHOWN ON SHEET SS3, DETAIL 'C', EXCEPT IT SHALL BE 12 INCHES IN LENGTH WITH THREE TIGHTNING BOLTS.

D PIPE REPAIR
NOT TO SCALE

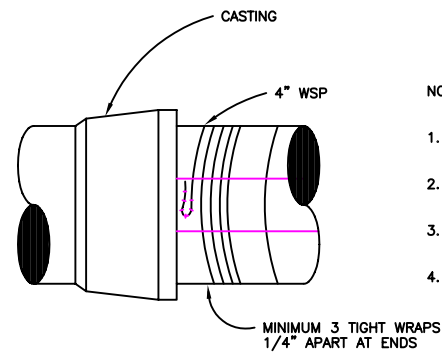

- NOTES:
1. TYPE 45" AND 60" WSP HOUSE SERVICE LINES SHALL BE STAPLED ON TOP OF PIPE.
 2. SIX GALVANIZED STAPLES TO BE USED AT EACH WIRE ENDING.
 3. STAPLES NOT TO PENETRATE INNER SURFACE OF PIPE.
 4. STAPLES EVERY 18" THROUGHOUT THE LENGTH OF THE PIPE SECTION.

B TYPICAL WSP STAPLE DETAIL
NOT TO SCALE



DATE	REVISION	BY

PLAN SCALE: NOT TO SCALE
PLOT SCALE: 1=1

DESIGNED	APPROVED
DRAWN NBB	
CHECKED MJB	USA ENGINEER
DATE FEB 1998	FILE: STANDARD DETAILS SS2



SANITARY SEWER SYSTEM
CONNECTIONS, ADAPTATION, FLUSHWELL, REPAIR