



# SERVICE LINE STANDARDS

Revised: July 2011



PO Box 80370  
3691 Cameron Street  
Fairbanks, AK 99708  
(907) 479-3118

[www.akwater.com](http://www.akwater.com)  
[usainfo@akwater.com](mailto:usainfo@akwater.com)

# TABLE OF CONTENTS

|  |    |
|--|----|
| <b>INTRODUCTION</b> .....                                    | 4  |
| <b>SECTION 1 GENERAL</b> .....                               | 5  |
| 1.1 Scope.....   | 5  |
| 1.2 Liability.....   | 5  |
| 1.3 Intent.....  | 5  |
| 1.4 Ownership.....   | 5  |
| 1.5 Definitions.....   | 5  |
| 1.6 Responsibility.....                                      | 6  |
| <b>SECTION 2 PROCEDURE FOR OBTAINING A NEW SERVICE</b> ..... | 6  |
| 2.1 Information to Obtain.....                               | 6  |
| 2.2 Service Line Size and Installation.....                  | 6  |
| 2.3 Application for Service.....                             | 7  |
| <b>SECTION 3 GENERAL REQUIREMENTS</b> .....                  | 8  |
| 3.1 Standards.....   | 8  |
| 3.2 Scope of Utility Personnel Work.....                     | 8  |
| 3.3 Required Inspection.....                                 | 9  |
| 3.4 Connection of Service Lines to Main.....                 | 9  |
| 3.5 Excavation.....  | 9  |
| 3.6 Backfill.....  | 10 |
| 3.7 Compaction Requirements.....                             | 10 |
| 3.8 Permits.....   | 10 |
| 3.9 Insulation.....  | 10 |
| 3.10 Service Line Placement.....                             | 11 |
| <b>SECTION 4 WATER SERVICE REQUIREMENTS</b> .....            | 12 |
| 4.1 Pitorifice Saddle Connection.....                        | 12 |
| 4.2 Tee Connection.....                                      | 14 |
| 4.3 Property Loop.....                                       | 16 |
| 4.4 Material Standards.....                                  | 17 |
| 4.5 Pipe Fittings.....                                       | 17 |
| 4.6 Circulating Loop and Water Meter.....                    | 18 |
| 4.7 Shut-Off Valve.....                                      | 18 |
| 4.8 Private Circulation Pump.....                            | 19 |
| 4.9 Fire Sprinkler Systems.....                              | 20 |
| 4.10 Seasonal Water Services.....                            | 22 |
| 4.11 Fire Hydrants.....                                      | 22 |
| 4.12 Commissioning.....                                      | 23 |
| 4.13 Cross Connections.....                                  | 24 |
| 4.14 Inspection.....   | 24 |
| 4.15 Heat Exchangers.....                                    | 25 |
| 4.16 Backflow Prevention.....                                | 25 |

**SECTION 5 WASTEWATER SERVICE REQUIREMENTS .....26**  
5.1 Connection .....26  
5.2 Stub Outs.....27  
5.3 Material Standards.....28  
5.4 Service Requirements.....28  
5.5 Cleanouts.....30  
5.6 Backwater Valves .....30  
5.7 Lift Stations .....31  
5.8 Pre-Treatment.....32

## INTRODUCTION

Thank you for your interest in Utility Services of Alaska, hereinafter referred to as (USA). USA provides administrative support to both College Utilities Corporation (CUC) and Golden Heart Utilities (GHU). We have prepared the following information to guide you and/or your contractor through the required steps in the service line installation process and to serve as the inspection guideline prior to connection. This booklet was designed as a guideline to supplement the Utilities' rates, charges, and rules and regulations as filed with the Regulatory Commission of Alaska (RCA).

These standards are modified from time to time, generally on an annual basis during the first quarter of the year. When substantive revisions occur, the Utilities will publicly notice its customers. These standards will be enforced. It is the responsibility of the individual to ensure they have the most recent version of the Utilities' Service Line Standards. To confirm that you have the most recent version, please check our website at [www.akwater.com](http://www.akwater.com) or contact customer service. You may also sign up at our website to be added to our mailing list for Service Line Standard updates. You will then be notified by email when new standards are issued.

Copies of CUC/GHU's water and wastewater tariffs, including all rates, charges, rules and regulations are available at USA's office for public inspection during regular business hours or you may view them or download them from our website at [www.akwater.com](http://www.akwater.com).

If you have any questions after reading this booklet, please contact our office for further information. We look forward to serving you and providing you with high quality drinking water and wastewater treatment services.

## SECTION 1 GENERAL

### 1.1 SCOPE

This specification covers the acceptable design and construction features for connection to CUC and/or GHU water and wastewater systems and will serve as the official inspection guideline prior to connection by the Utility. Deviation from this standard is permitted only by written consent of the Utility.

### 1.2 LIABILITY

CUC and/or GHU assume no responsibility or liability concerning the suitability or applicability of this standard to the requirements of the customer.

### 1.3 INTENT

It is not the intent of this standard to supersede tariff regulations, but rather to provide designers, contractors, and customers a basic guide for design and installation of underground piping systems to ensure compatibility with the Utilities' system.

### 1.4 OWNERSHIP

The extent of ownership by the Utility is limited to water or wastewater mains, pitorifice/corporation stop and/or service valve and tee, wastewater saddle, water meter, and Automatic Meter Reading (AMR) equipment. All other piping, fittings, valves, pumps, and other material, whether required by law, necessity, or this Standard **are the sole responsibility of the customer.**

### 1.5 DEFINITIONS

The following definitions apply to this Standard:

Utility: College Utilities Corporation (CUC) and/or Golden Heart Utilities (GHU).

Customer: That person making contact with the Utility for the purpose of obtaining water and/or wastewater service. The customer has certain responsibilities and liabilities detailed in Section 3 of this Standard.

Designer: Any person who designs the system governed by this specification.

Installer: Any person acting on behalf of the customer who will perform installation, excavation, insulation, or any other work relating to complete or partial accomplishment of connection to the Utility system. The installer is responsible to the customer to provide a system which conforms to the requirements of this Standard.

## 1.6 RESPONSIBILITY

The customer is responsible for obtaining verification from the designer and installer that all design and installation work is in conformance with this Standard.

The customer and installer are responsible for meeting the requirements of the CUC/GHU tariff. The customer is responsible for obtaining all required permits. This includes, but is not limited to, Alaska Department of Transportation Right of Way permit, Fairbanks North Star Borough Road Permit, City of Fairbanks Street Digging Permit, or other as required. The customer and installer will be held accountable for violations of the CUC/GHU tariffs and/or damage to Utility facilities resulting from failure to comply with the requirements of the CUC/GHU tariffs and this Standard.

The installer is responsible for meeting the applicable requirements of this Standard, the Uniform Plumbing Code, and the Construction Code of the Occupational Safety and Health Standards except as modified by this Standard.

## **SECTION 2 PROCEDURES FOR OBTAINING A NEW SERVICE**

### 2.1 INFORMATION TO OBTAIN

Call or visit USA's office at 3691 Cameron Street, Suite 201, 907-479-3118 for information on:

- a) The availability of service.
- b) The location of mains.
- c) Whether or not assessments (i.e., Contribution In Aid of Construction (CIAC) fees) have been paid.

### 2.2 SERVICE LINE SIZE AND INSTALLATION

The type of connection provided by the Utility will depend upon piping sizes, customer material preferences and the water or wastewater main to which the customer will connect. The person requesting connection is required to state the type and size of piping that he intends to install. Each leg of the dual water service line shall be a minimum of ¾" nominal diameter.

- a) Determine the size of the service line based on number of units in the building for residential service and square footage of building for commercial service.

- b) Water: Standard residential water service is a three-quarter (3/4") inch service line. **For water service connections over two (2") inches in diameter, check with the Utility well in advance of the anticipated connect date to ensure materials are available for the connection.** (Refer to Section 4 for available service configuration.) A service connection shall serve no more than one (1) lot. No service connection may cross a lot line other than that for which it is intended to provide service unless an easement has been provided. A structure shall be served by a single service connection. Where multiple buildings occupy a single lot, there shall be one (1) service connection for each building on a lot, unless the Utility has approved a branched service extension in writing.
- c) Wastewater: Wastewater services are generally four (4") inch (minimum) with six (6") inch for special cases. Wastewater service line size is based on the number and type of plumbing fixtures in the proposed building. Refer to Section 5 for available service configuration. A service connection shall serve no more than one (1) lot. No service connection may cross a lot line other than that for which it is intended to provide service unless an easement has been provided. A structure shall be served by a single service connection. Where multiple buildings occupy a single lot, there shall be one (1) service connection for each building on a lot, unless the Utility has approved a branched service extension in writing. All service lines shall be installed with an approved backwater valve. See Section 5.6 (a)(b).

### 2.3 APPLICATION FOR SERVICE

The customer is responsible for making application for service with USA Customer Service prior to requesting field location of, or connection to the mains.

Application: Apply for service and pay necessary fees at USA's office located at 3691 Cameron Street, Suite 201, Fairbanks, Alaska 99709.

For residential structures, the building owner may perform the hookup, provided that the owner does the actual installation. If the actual installation is not to be performed by the owner, then the work must be performed by competent plumbers holding valid Alaska Department of Labor Journeymen Plumber Cards (required by Alaska State Law).

Further, the owner must accept liability for any damage done to Utility property by themselves, their contractor, or a person acting on their behalf.

Responsibility to Locate Underground Utilities: The customer or his installer shall be responsible for determining the location of all underground utilities and shall be responsible for any damages to underground utilities caused by the work. Possible underground utilities to be located are: telephone lines, cable TV lines, electrical lines, street lights, water and wastewater mains, gas mains, storm drains, etc. If a line location is needed for water or wastewater mains, an appointment must be made in advance. Alaska Statutes require a forty-eight (48) hour notice, however, based on workflow, the Utility can normally support a twenty-four (24) hour notice. Water and wastewater locates are provided without charge.

Prior to excavation, the property owner must:

- a) Sign an application for service to the property.
- b) Sign a Contribution In Aid of Construction (CIAC) agreement.
- c) Secure a street-digging permit from the City of Fairbanks, Fairbanks North Star Borough, or the DOT if within a street right-of-way.
- d) Secure any other permits required.

### **SECTION 3 GENERAL REQUIREMENTS**

#### **3.1 STANDARDS**

Only work, materials, and tools meeting acceptable standards shall be permitted.

- a) All plumbing shall conform to the standards set forth in the most recent edition of the Uniform Plumbing Code.
- b) All work and materials shall be free of defects and leaks.
- c) All materials used shall be new.

#### **3.2 SCOPE OF UTILITY PERSONNEL WORK**

Utility personnel will shut off water main lines, remove insulation from main, install saddles for both water and wastewater services, pitorifices, tees, valves, and thaw wire, reactivate the water main line, and install the water meter on Tuesdays and Thursdays of each week. This, together with the inspection of all materials and work, will constitute the scope of Utility personnel work unless specific arrangements have been made in writing for the Utility to do other work for the Customer.

#### **3.3 REQUIRED INSPECTION**

Inspection of the facilities is the responsibility of the Utility. Each phase of work must be inspected by Utility personnel before going on to the next phase. Inspection No. 1 inspects the service line for correct installation of materials. Inspection No. 2 inspects the amount of insulation on a service line and re-insulation on the main line. For additional information concerning the inspections, please see Section 4.6 and 4.13. In the event of conflicts between this Standard and other Standards, the following governance shall apply:

1. CUC/GHU tariffs on file with RCA
2. This specification
3. Uniform Plumbing Code

#### 3.4 CONNECTION OF SERVICE LINES TO UTILITY MAIN

Connections to water and wastewater mains will be made on Tuesdays and Thursdays during normal Utility working hours. No person, other than Utility personnel, shall cut or bore any holes in a water or wastewater main or attempt to install a connection.

Alaska Statutes require a forty-eight (48) hour notice prior to connection to the main, however, based on workflow, the Utility can normally support a twenty-four (24) hour notice.

#### 3.5 EXCAVATION

The customer, or his contractor, shall do all the excavating, including the excavation around the main line necessary to install saddles, pitorifices, tees, and valves.

ANY DAMAGE to the main will be repaired by Utility personnel and billed to the contractor or customer.

The installer is responsible for protection of private and public property and provisions of a safe excavation for connection. All excavations shall meet the requirements of Alaska Department of Labor and Federal OSHA Regulations. The installer shall furnish all necessary construction and safety equipment including shoring, de-watering pumps, excavation equipment, ladders, barricades and signs. The installer shall remove all standing and inflowing water from the excavation. Connections will not be made in cases of improper excavation, excessive groundwater, or other unsafe conditions.

#### 3.6 BACKFILL

Backfill service trench by hand a minimum of twelve (12") inches above the pipe and compact as necessary. Fill remainder by mechanical means and compact as necessary.

### 3.7 COMPACTION REQUIREMENTS

Compaction in street right of ways must meet Alaska Department of Transportation, City of Fairbanks or Fairbanks North Star Borough compaction requirements.

Compaction beneath the Utility main and to a point twelve (12") inches above the main shall be 95% or greater.

### 3.8 PERMITS

Information on applying for Fairbanks North Star Borough street digging permits may be made by calling the Public Works department at 459-1345. Information on City of Fairbanks permits is available by calling 459-6770. You may also need to contact the Alaska Department of Transportation at 451-5400 or 451-5179.

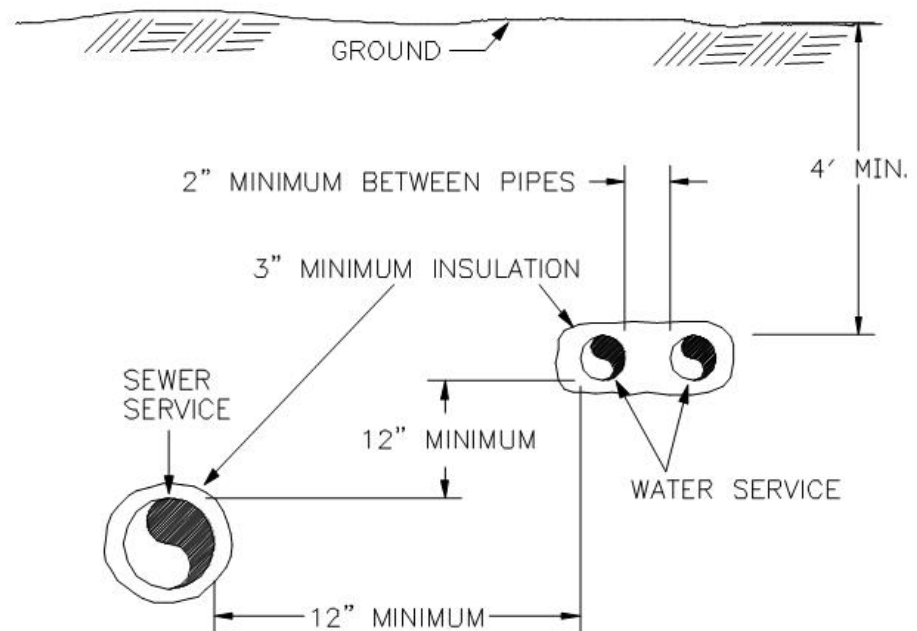
### 3.9 INSULATION

Insulation material shall be sprayed urethane foam; SWD Quik-Shield 212VTX or approved equal. Applicator shall demonstrate prior experience of at least two (2) years and the Utility shall be the sole judge of the qualifications of system, application method, and applicator.

- a) For water and wastewater service lines with a four (4') foot or deeper bury, the minimum insulation thickness shall be three (3") inches on the top, sides and bottom.
- b) For water and wastewater service lines shallower than four (4') feet, the minimum insulation thickness shall be four (4") inches on the top, sides, and bottom, including where water services rise vertically near an outside wall. Additional insulation will be required by the Utility for conditions such as shallow service lines installed under driveways and sidewalks, and vertical service lines.
- c) Any hole cut in an outside concrete wall for service must be sprayed full of insulation.
- d) The customer or his contractor shall be responsible for re-insulating the main at the service connection.

### 3.10 SERVICE LINE PLACEMENT

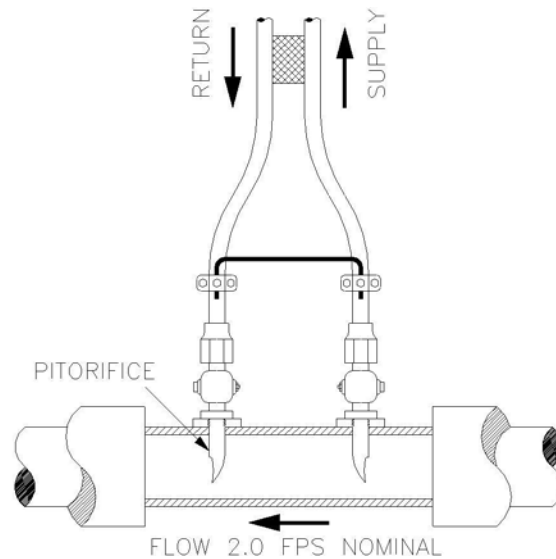
- a) Water service piping shall be installed such that a two (2") inch minimum horizontal separation is provided between supply and return.
- b) Buried piping shall be installed with a minimum four (4') foot soil cover. Exceptions to this rule must be approved by the Utility.
- c) The service line depth shall be increased to provide protection against breakage or damage from heavy vehicles moving on the surface of the ground over or adjacent to such connections.
- d) A minimum one (1') foot horizontal separation from wastewater services shall be provided. In addition, the bottom of the water service piping shall be installed at least twelve (12") inches above the top of the wastewater service piping. These separation distances are required by the Alaska Department of Environmental Conservation. The water service pipe shall be placed on a solid shelf excavated at one side of the common trench.
- e) If the requirements of this section cannot be met, then it is necessary that the service lines be installed in two (2) separate trenches a minimum of ten (10) feet apart.



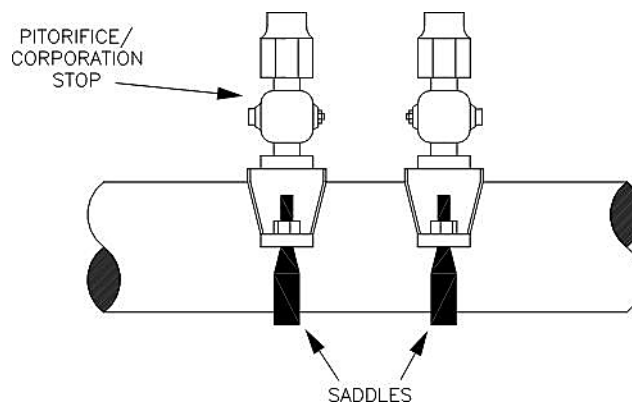
**Figure 1: Buried Pipe Separation**

## SECTION 4 WATER SERVICE REQUIREMENTS

### 4.1 PITORIFICE SADDLE CONNECTION

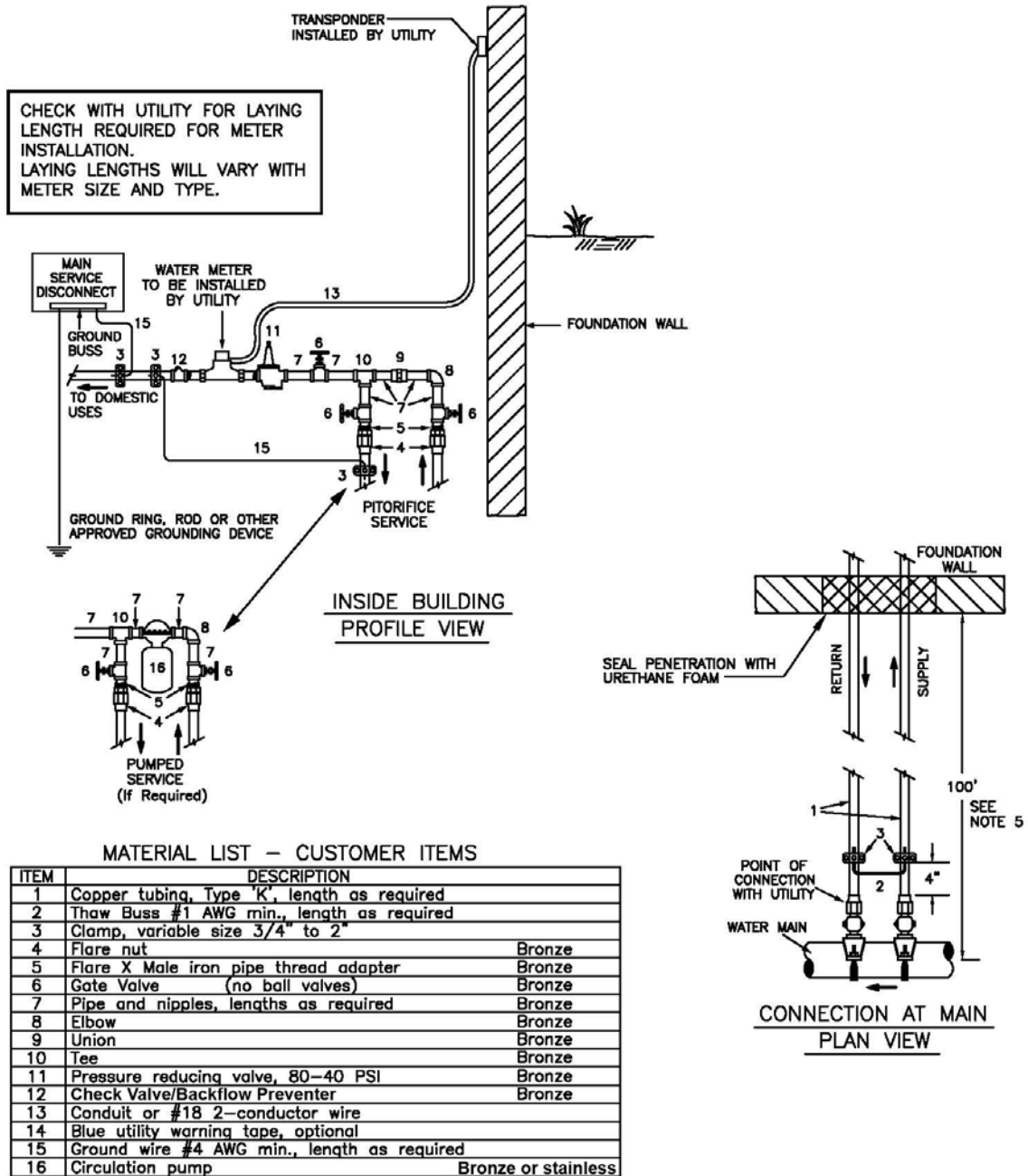


**Figure 2: Pitorifice Circulation**



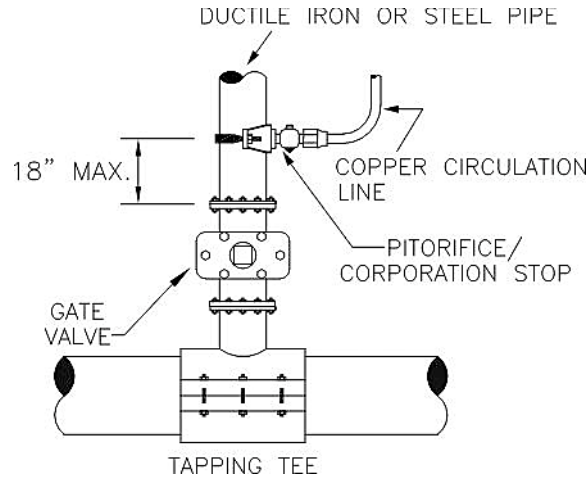
**Figure 3: Pitorifice Saddles**

Pitorifices with corporation stops are installed and available for services three quarter (3/4") inch, one (1") inch, one and one-half (1-1/2") inch, and two (2") inch. Saddles and pitorifices/corporation stops are installed by the Utility at the time of connection. Three quarter (3/4") inch saddles are standard for most residential services. See Figure 4 for typical water service. (Saddle connections are not allowed on transmission mains if a distribution main is available.)



**Figure 4:** Typical Pitorifice Circulating Loop Water System  
(Customer to supply all items on material list)

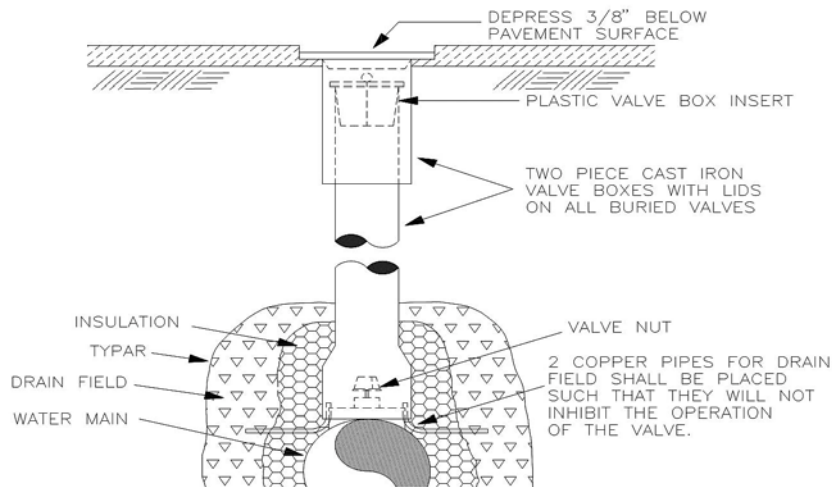
## 4.2 TEE CONNECTION



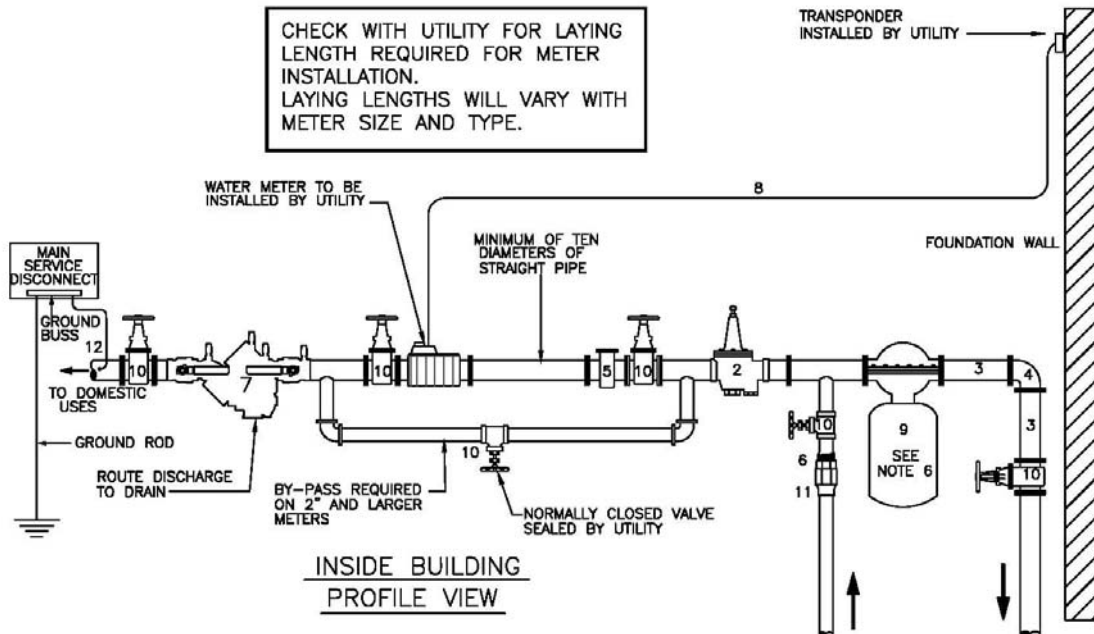
**Figure 5: Typical Tee Connection**

Where customer design requires a connection larger than two (2") inches; tees and gate valves are used. Utility personnel will install the tee and gate valve. The gate valve will be a minimum of six (6") inches. Customer will be responsible for providing reducers if the service is to be less than six (6") inches. Gate valve end connection will normally be mechanical joint. Other configurations are available based on customer's requirements. Contact USA Customer Service for further information. See Figure 7 for typical large service.

Valve boxes including risers and/or collars provided by the Utility for access to Utility service valves shall be placed on valves by the installer in conjunction with backfill and street repair. Valve boxes shall be plumb, straight, and clean prior to acceptance by the Utility. Assistance with final adjustment of valve box tops will be provided upon 24-hour notification of the Utility.

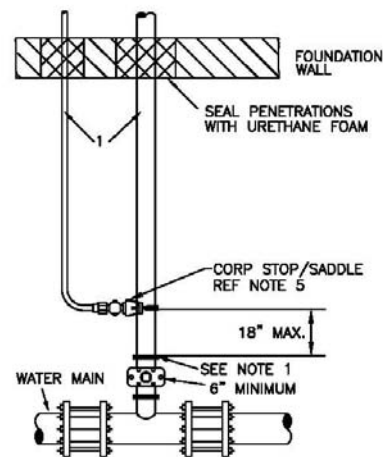


**Figure 6: Valve Box**



**MATERIAL LIST – CUSTOMER ITEMS**

| ITEM | DESCRIPTION                                 |
|------|---|
| 1    | Piping per section 4.4                      |
| 2    | Pressure reducing valve, 80–40 PSI          |
| 3    | Pipe and nipples, lengths as required       |
| 4    | Elbow                                       |
| 5    | Plate Strainer (Supplied by Utility)        |
| 6    | Flare X Male iron pipe thread adapter       |
| 7    | Check valve/Backflow Preventer              |
| 8    | Conduit or #18, 2-conductor wire            |
| 9    | Circulation pump (Mandatory)                |
| 10   | Gate valve (only)                           |
| 11   | Flare nut                                   |
| 12   | Ground wire #4 AWG min., length as required |



**NOTES:**

1. Tee and valve provided by Utility.
2. Water service pipes shall have a level or positive grade from the water main to the building (no humps or dips) to prevent air traps.
3. Meter shall be a minimum of 1' and a maximum of 4' above floor level.
4. Install circulation pump according to manufacturer's recommendations.
5. Use of a 90° flare fitting is required on 1-1/2" or larger copper circulation line connections

**Figure 7: Large Water Service (2" or larger)  
(Customer to supply all items on material list)**

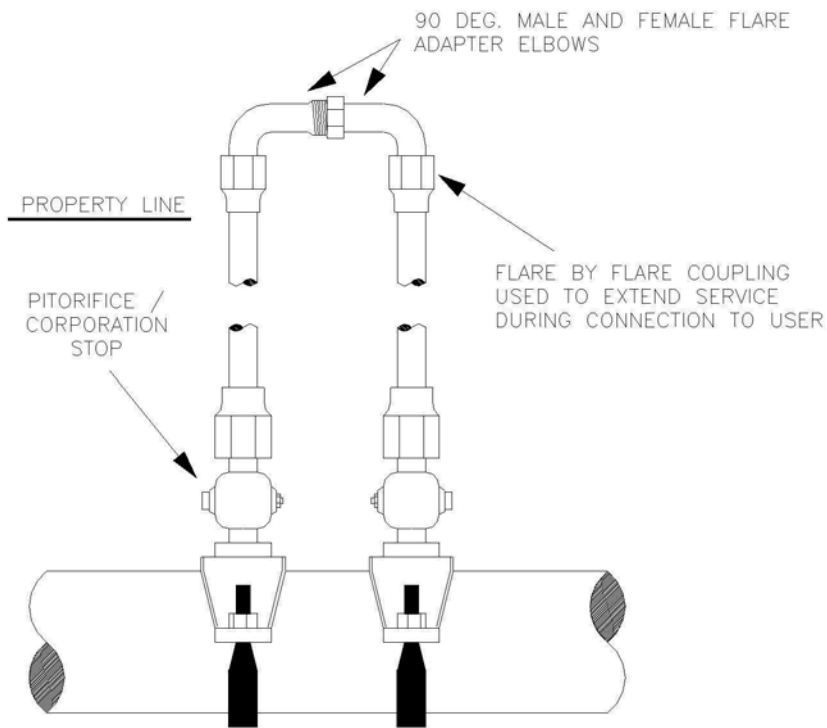
### 4.3 PROPERTY LOOP

Pitorifice service loops have occasionally been installed with new water mains at the time of construction and stubbed out to the property line. No warranty as to the current condition and proper function of the property loop piping can be made by the Utility. Complete shutoff can only be accomplished by excavating to the main.

Service loops belong to the property owner of the lot served by the loop. The property owner shall be responsible for the maintenance and all other costs associated with the service connection loop.

The Utility will record at the Fairbanks District Recording Office “NOTICE OF NON-COMPLIANCE OF UTILITY SERVICE LINE HOOKUP”. This will notify all interested parties that the service stub exists and is the property owner’s responsibility.

Electronic markers, as manufactured by 3M, shall be placed over the ends of all property loops.



**Figure 8:** Temporary Property Loop

#### 4.4 MATERIAL STANDARDS

Type "K" soft drawn copper for sizes three-quarters (3/4") of an inch, one (1") inch, one and one-half (1-1/2") inch and two (2") inch. Any joints in the service loop below ground shall employ brass flare type connections. **No compression type unions shall be used.**

- a) Ductile iron pipe is preferred for pipe sizes four (4") inch, six (6") inch and eight (8") inch. Ductile iron pipe shall conform to the latest revision of AWWA C151. Joints may be push on (Tyton), or mechanical joint. Joints shall conform to AWWA C111. Ductile iron pipe shall be thickness Class 50, cement mortar lined.
- b) Steel pipe (Schedule 40) is allowed for sizes two (2") inch, three (3") inch, four (4") inch, six (6") inch, and eight (8") inch. **Galvanized pipe is not permitted.** Pipe shall be butt welded or connected with dresser type couplings with appropriate restraints. **Threaded pipe is not permitted underground.**
- c) All pipe and fittings shall meet the requirements of the National Sanitation Foundation (NSF) 61.

#### 4.5 PIPE FITTINGS

- a) In a service constructed from copper, all fittings on the circulating loop shall be threaded bronze or brass material. Soldered joints are not permitted in the circulation loop. Soldered joints are permitted only in the domestic branch after the check valve or approved backflow prevention device. Brass flared fittings shall be used below ground to join copper tubing on long runs.
- b) Ductile iron pipe and fittings shall conform to AWWA C153.
- c) Steel pipe systems shall utilize flanged valves and welded or threaded Schedule 40 fittings above ground. **Threaded joints are not permitted below ground.**
- d) Bronze or brass fittings shall not be used in services constructed from steel, and steel fittings shall not be used in services constructed from copper. Galvanized fittings are not permitted.
- e) Flanged connections for underground piping runs and underground fittings are not acceptable except for valves.
- f) All piping two (2") inch and larger, that is not welded, shall be restrained by use of anchors, restraining rods and/or thrust blocks wherever necessary.

- g) Non-toxic thread sealant is required for all threaded joints on the service loop. Threaded pipe below ground is not authorized. **Solder joints shall not be used between the Utility water main and the check valve.** Water service lines shall be sloped to the main and installed as straight as possible (except for angle points).
- h) Lead free solder is required in the domestic piping.

#### 4.6 CIRCULATING LOOP AND WATER METER

The circulating loop and meter shall be located in a warm, accessible area and remain so during the life of the service.

The plumbing must be installed in such a manner that will allow the meter to be installed horizontally with the register upward.

The meter will be installed during the first inspection. The Utility requires that all the components of the water service be present at the time Utility personnel arrive on site to connect the service to the water main and to do the first inspection. If all of the components, such as the PRV, check valve or backflow preventer, and service loop are not present and complete, Utility personnel will not install the saddles and will reschedule the appointment for a later time. If all of the components are present and complete, Utility personnel will install the saddles, the water meter, and do the first inspection.

The customer is responsible at all times for protecting the water service and the loop within the building, as well as the meter, from freezing and breaking and for any other damage that may occur to those facilities.

The size of meter is determined prior to installation of the service. Meter size will normally be the same as service size unless otherwise specified. The Utility has discretionary authority to select the meter size and type required to facilitate accurate metering while satisfying service flow requirements. Customer/installer shall leave the correct space (dimension) for Utility personnel to install the meter. Check with the Utility for laying length required for meter installation. Laying length will vary with meter size and type.

Services two (2") and larger shall have a by-pass line around the meter for meter maintenance work.

Meter shall be a minimum of one (1') and a maximum of four (4') above floor level.

#### 4.7 SHUT-OFF VALVE

A gate valve must be installed between the circulation loop and the meter for customer use. The customer shall not use the valves on the circulating loop.

These valves are to remain open for proper circulation in the service lines. Closing one of these valves could cause the service to freeze during winter months.

#### 4.8 PRIVATE CIRCULATING PUMP

Customer is responsible for providing and maintaining a circulation pump if:

- a) The length of either the supply or return piping run exceeds one hundred (100') feet.
- b) The service is connected to a main with low flow velocities as determined by the Utility.
- c) Continued experience demonstrates that individual services do not possess adequate thermal protection (i.e., they habitually freeze up).

Pump installation is subject to approval by the Utility. Pump shall be installed downstream of the supply valve, and upstream of the tee for the domestic branch. Pump shall be sized to provide a minimum flow velocity of 0.1 feet per second in the largest pipe or ten (10) gallons per minute, whichever is larger, without consideration of the contributions of pitorifices. Pump shall be installed such that flow direction through the pump is the same as that through the main. Circuit setters or other flow control devices are not allowed in pumped loops. Flow direction for the main is available from USA Customer Service Department.

Circulation pumps shall conform to the following requirements:

- a) All services one hundred (100') feet or less in length (one way):  
Horsepower: 1/12 HP  
Maximum flow at zero head: 22 GPM  
Maximum head at zero flow: 19 feet  
Grundfos UP 25-64 SF or equal  
Rated for 150 PSI
- b) All household services between one hundred (100') feet and five hundred (500') feet in length (one way):  
Horsepower: 1/12 HP  
Maximum flow at zero head: 25 GPM  
Maximum head at zero flow: 30 feet  
Grundfos UP 26-96 BF or equal  
Rated for 150 PSI
- c) All commercial services between one hundred (100') feet and five

hundred (500') feet in length (one way):  
Horsepower: 1/6 HP  
Maximum flow at zero head: 45 GPM  
Maximum head at zero flow: 25 feet  
Grundfos UP 43-75 BF or equal  
Rated for 150 PSI

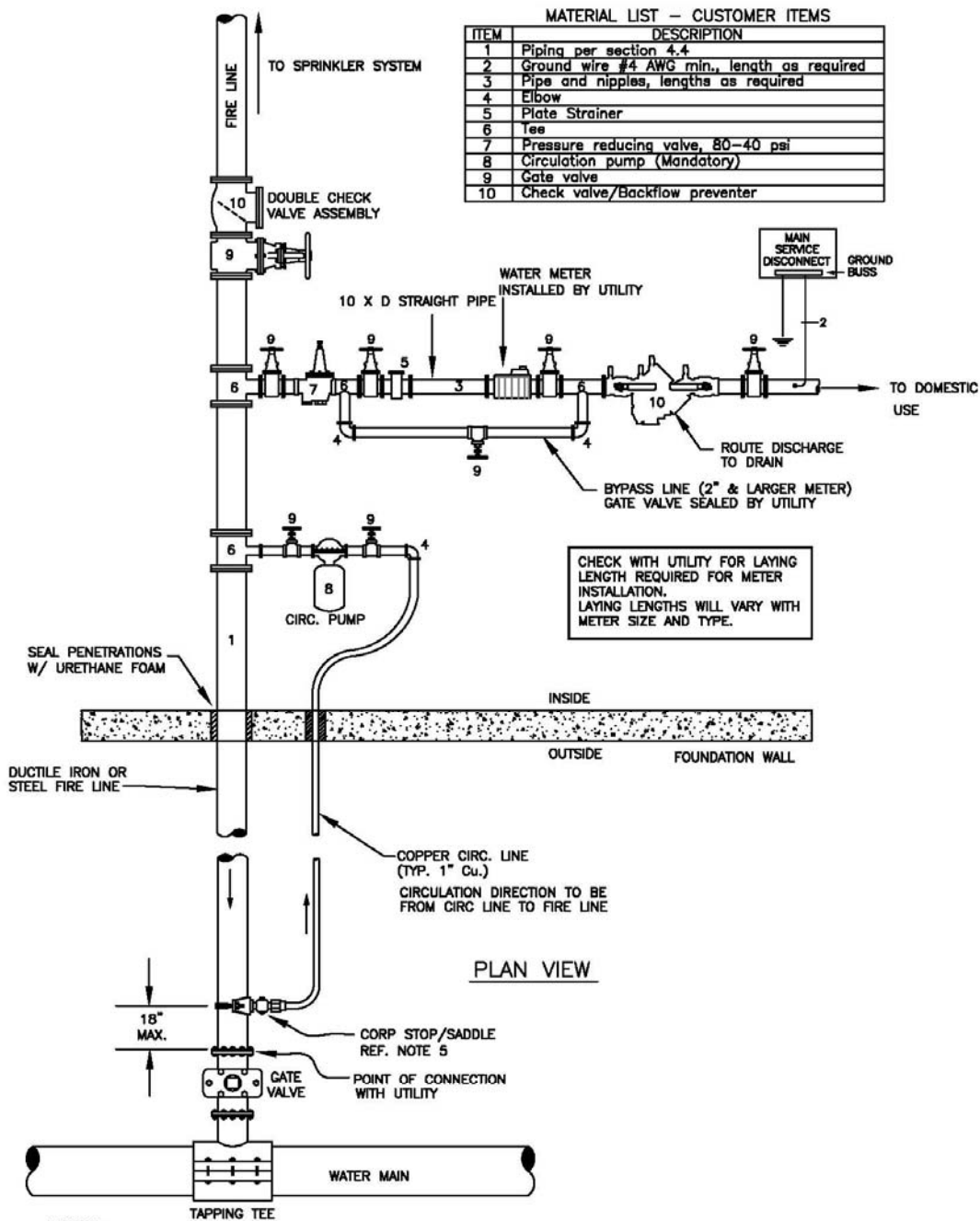
- d) Any service which services more than one structure and is over five hundred (500') feet in length shall utilize a pumping system that is designed with consideration given to pump load requirements, circulation path, and heat balance. Calculated thermal degradation shall be limited to two (2° F) degrees Fahrenheit over the entire distance through the service piping. A circulation plan is required.
- e) The private circulating pump shall have a bronze or stainless steel body.

#### 4.9 FIRE SPRINKLER SYSTEMS

Refer to Figure 9 for specific elements to be included in fire sprinkler system underground piping. All items shown in the drawing and identified as under customer ownership are the sole responsibility of the customer to furnish and maintain.

An approved backflow prevention device (usually a double check valve assembly) shall be installed in the sprinkler line, to prevent reintroduction of aged fire-line water into the customer's domestic water branch or into the Utility's system.

The installation of a fire booster pump is prohibited on the CUC/GHU water systems without advance written approval from the Utility.



**NOTES:**

1. Tee and valve provided by Utility.
2. Water service pipes shall have a level or positive grade from the water main to the building (no humps or dips) to prevent air traps.
3. Meter shall be a minimum of 1' and a maximum of 4' above floor level.
4. Install circulation pump according to manufacturer's recommendations.
5. Use of a 90° flare fitting is required on 1-1/2" or larger copper circulation line connections

**Figure 9: Water Service with Fire Sprinkler**

#### 4.10 SEASONAL WATER SERVICES

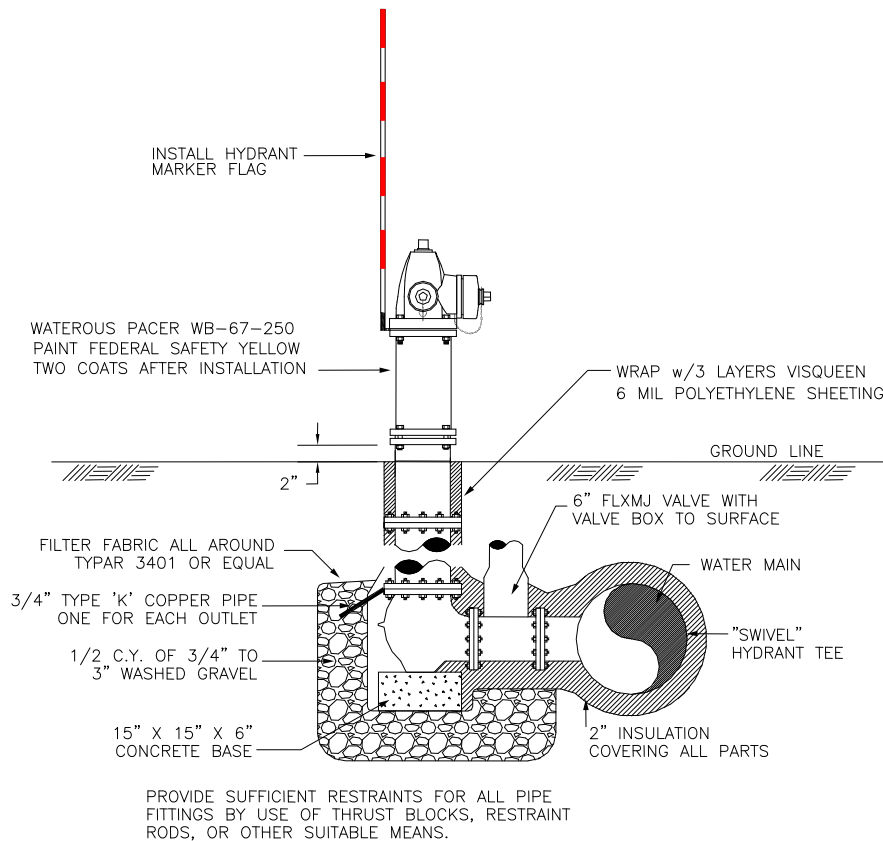
Any service that serves a facility that is unoccupied during the winter months is considered a seasonal water service. If the seasonal service is not circulated, or if the service entry is not located in a heated area, the service must be configured with a gate valve (6" minimum) off the main to facilitate annual shutdowns. Seasonal water services serving outdoor facilities must be configured with a man accessible meter pit with an approved backflow prevention device. Note that drain valves, plugged tees or other similar appurtenances are not allowed between the main and the meter

For non-circulating seasonal services, the Utility cannot guarantee a perfect shutoff at the main, and cannot be held responsible for damage resulting from such leaks. Therefore, the Utility strongly recommends that water service entries are located in a heated area and maintained with continuous circulation.

#### 4.11 FIRE HYDRANTS

If a fire hydrant is required on customer owned service lines by the fire department, all equipment and methods of installation shall be designed and installed in accordance with the following:

- a) Hydrants shall be Waterous Pacer WB-67-250 or approved equal. Approval must be granted by the Utility on a case by case basis prior to construction.
- b) The hydrant shall be installed as a part of the building water system and shall be protected from freezing by the building circulation pump.
- c) Install a hydrant marker flag, fifty-four (54") inches minimum length, Nordic Flexi Flag.
- d) Each hydrant and guard post shall be painted with two coats of Federal Safety Yellow industrial enamel.
- e) Completed fire hydrant shall be contributed to the Utility to own and operate.



**Figure 10: Fire Hydrant**

#### 4.12 COMMISSIONING

All piping shall be hydrostatically tested, disinfected, and flushed. The installer shall furnish all temporary hose, pipes, pumps, and fittings required to accomplish this work.

**Pressure Testing:** Residential services shall be tested at main line pressure upon energizing the service. All pipe and fittings shall be free of any drips or leaks during visual inspection. Large commercial services (other than fire systems) will be tested at one hundred forty-five (145) pounds per square inch (psi) for College Utilities and ninety-five (95) pounds per square inch (psi) for connections to Golden Heart Utilities. Leak-down tests are required for pipe runs of over one hundred-fifty (150') feet, and shall be conducted in accordance with the current test procedure as published in the CUC/GHU Standards of Construction. See NFPA 13 and 24 for the applicable leakage rates for fire supply piping. Fire system test pressure shall be two hundred (200) psi for two (2) hours.

**Disinfection:** Disinfection of service lines over two (2") inches in diameter shall be with a chlorine solution which shall be of sufficient strength (300 PPM) to provide a contact kill of bacteria and shall remain in contact with all

inside surfaces of the piping for three (3) hours. Upon completing disinfection, the chlorinated water shall be flushed to a safe location and disposed of properly. One half (1/2) cup of Clorox bleach in five (5) gallons of water is approximately a 300 PPM solution.

Flushing: Upon connection of the installed pipe to the Utility mains, the pipes shall be full bore flushed. Flushed water shall be conveyed to a safe location away from the excavation. The flushing shall be sufficient to remove all debris and disinfectant solution.

BAC-T Testing: For water services 2" and larger, a water sample from the disinfected, flushed service line shall be submitted to a state certified drinking water laboratory for testing according to test method SM9223B-PA (coliforms in Drinking Water). Test results indicating absence of coliforms must be presented to the utility before the service valve can be opened. All costs associated with sampling and testing are the responsibility of the customer/installer. In the event of a failed test, disinfection, flushing and BACT testing shall be repeated at the expense of the customer/installer.

#### 4.13 CROSS CONNECTIONS

Cross connections to other sources of water or interconnection to other services are expressly prohibited. Any connection that can allow entry of untreated water or contaminated water into the Utility distribution system is forbidden.

#### 4.14 INSPECTION

The Utility shall exercise the power of inspection in conjunction with the connection of the service piping and installation of the water meter.

- a) Utility personnel shall examine the piping lengths, methods used to connect the lengths, and shall verify proper installation of isolation valves, couplings and unions prior to connection to the Utility water mains. Immediately following connection, Utility personnel shall install the thaw wire.
- b) The Utility personnel shall inspect the pipe insulation prior to backfilling. They shall also inspect the service piping indoors prior to installation of the meter. This inspection shall cover all piping from the loop isolation valves to the domestic piping system.
- c) The meter will be installed during the first inspection. The Utility requires that all the components of the water service be present at the time Utility personnel arrive on site to connect the service to the water main and to do the first inspection. If all of the components, such as the PRV, check valve, and service loop are not present and complete,

Utility personnel will not install the saddles and will reschedule the appointment for a later time. If all of the components are present and complete, Utility personnel will install the saddles, the water meter, and do the first inspection.

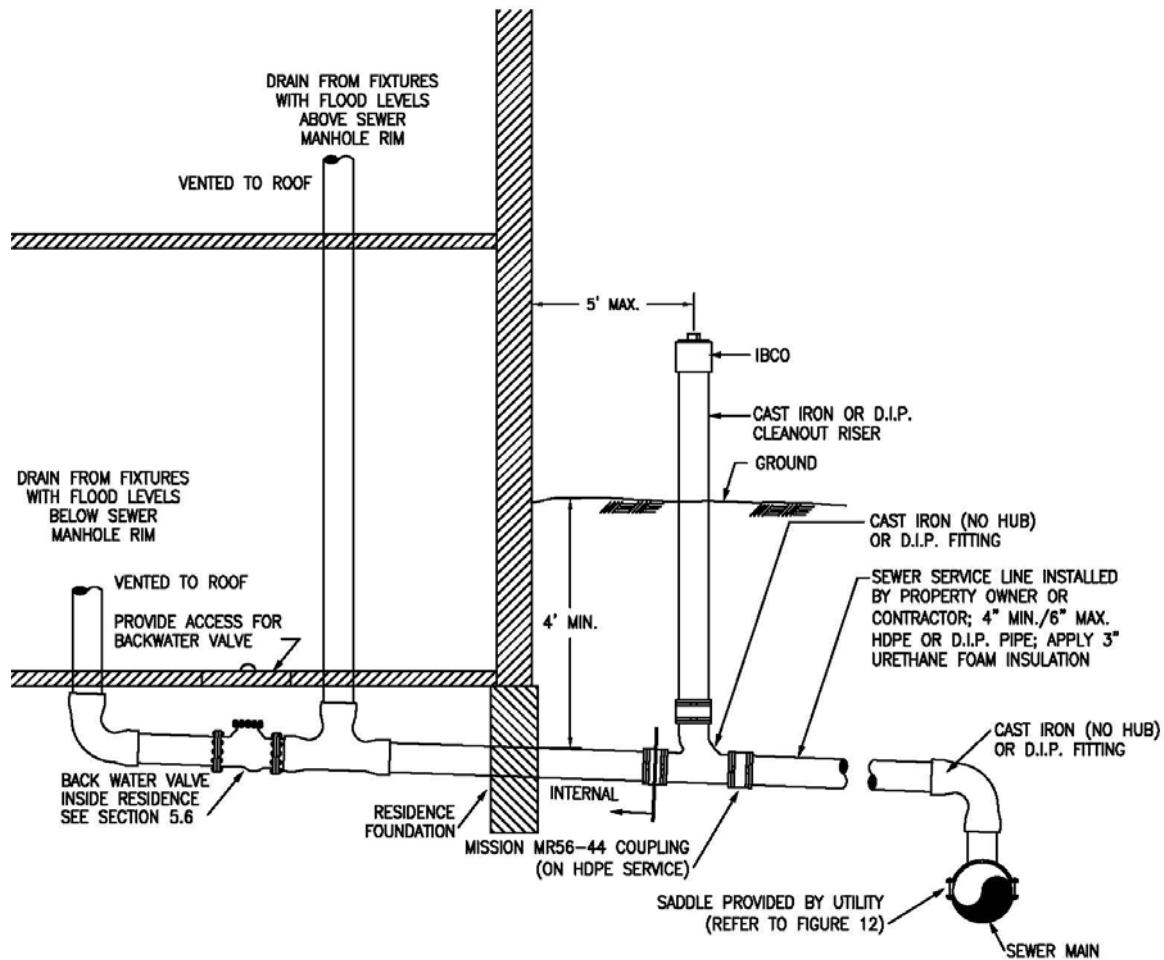
#### 4.15 HEAT EXCHANGERS

- a) The installation must conform to the Uniform Plumbing Code, the requirements of the Alaska Department of Environmental Conservation, the Utility's Service Line Standards, the utility's backflow prevention program and all other applicable rules and regulations of governing agencies.
- b) The chiller exchanger must be dual wall and constructed to potable water standards of construction, in accordance with SME code, Section VIII, Division 1, and be U.L. Listed.
- c) The Utility will have design approval, construction inspection and operational approval authority.
- d) Systems that remove heat from the Utility's system are not allowed.

#### 4.16 BACKFLOW PREVENTION

All water services must comply with the Uniform Plumbing Code Chapter 6 and the Utility's backflow prevention program requirements. The Utility has discretionary authority to determine the hazard level, and the type of backflow preventer (if any) required at any connected facility.

## SECTION 5 WASTEWATER SERVICE REQUIREMENTS



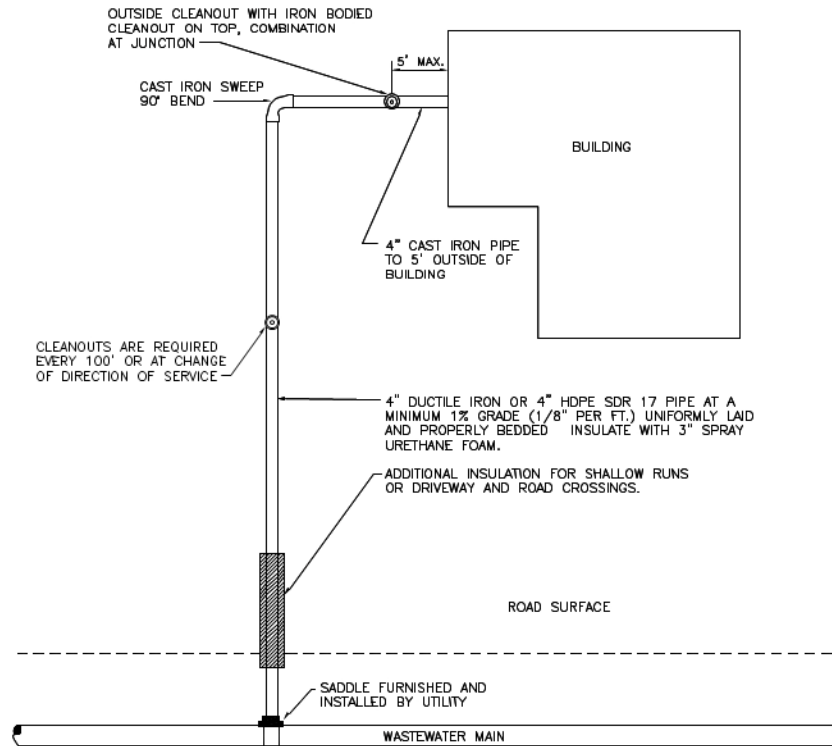
**Figure 11: Wastewater Service**

### 5.1 CONNECTION

A number of connection alternatives are acceptable depending upon the type of saddle, riser, fitting(s), and service line. The Utility will furnish and install the saddle connection to the main. All other work and material shall be provided by the customer/installer.

All wastewater service piping shall be ductile iron, or high-density polyethylene pipe. Wastewater service begins with the cleanout. Piping from the building to the cleanout is considered internal plumbing.

The building's wastewater service connection will be in compliance with Figure 11.1.



**Figure 11.1: Typical Wastewater Service**

## 5.2 STUB OUTS

The building's wastewater service may be connected to a Utility furnished wastewater service stub-out if available. Utility personnel shall verify the condition of the stub-out against blockage and structural integrity prior to final connection. No warranty as to the current condition and proper function of the stub out can be made by the Utility. Any repairs to the stub-out are the sole responsibility of the installer.

Service connection stubs belong to the property owner of the lot served by the stub. The property owner shall be responsible for the maintenance and all other costs associated with the service connection stub.

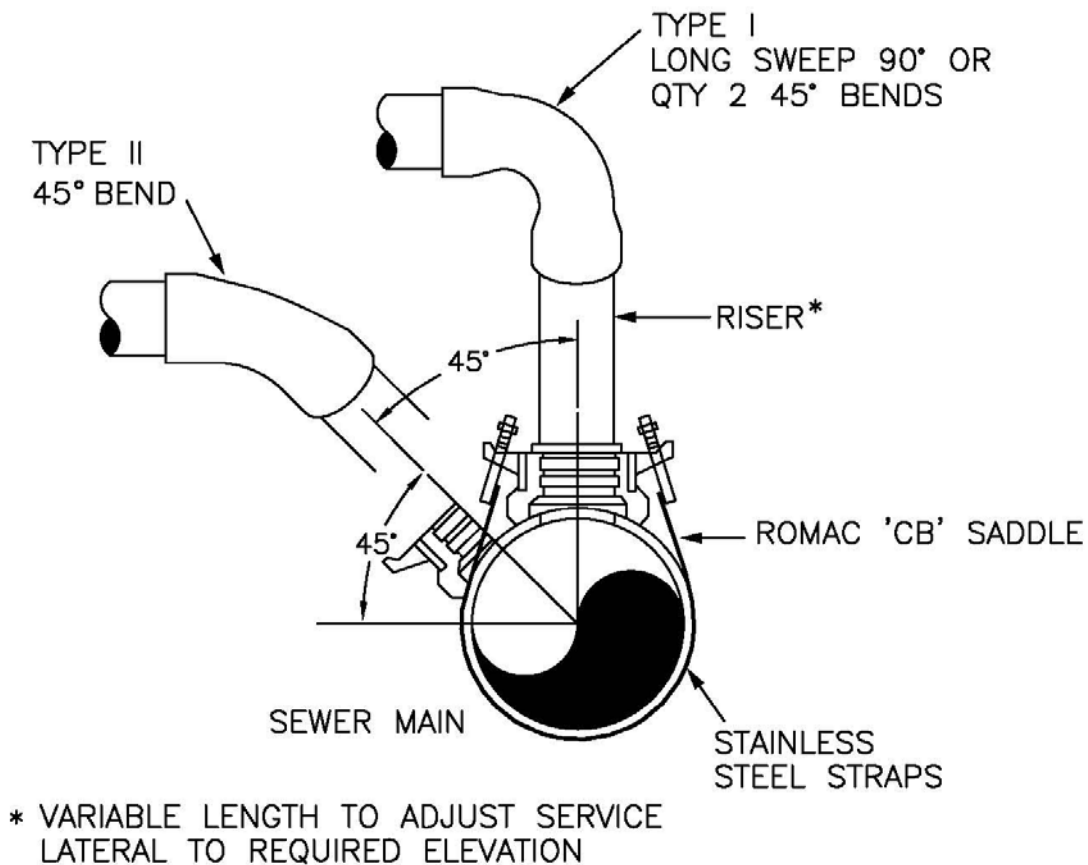
The Utility will record at the Fairbanks District Recording Office "NOTICE OF NON-COMPLIANCE OF UTILITY SERVICE LINE HOOKUP". This will notify all interested parties that the service stub exists and is the property owner's responsibility.

Electronic markers, as manufactured by 3M, shall be placed over the ends of all stub outs, which are installed for future use.

### 5.3 MATERIAL STANDARDS

- a) Ductile iron pipe shall conform to AWWA C-151 and shall be a minimum thickness class fifty (50). Ductile iron pipe shall be cement mortar lined. Cast iron pipe is not acceptable.
- b) High density polyethylene pipe shall be made from P.E. 3408 resin with a Cell Classification of 345434C in accordance with ASTM 3350-83 and shall conform to standard iron pipe size outside dimensions (IPS) having a wall thickness with a standard dimensional ratio (SDR) of 17.

### 5.4 SERVICE REQUIREMENTS



**Figure 12:** Connection Schemes

- a) Wastewater service connections shall be cut or bored into wastewater mains. The Utility claims sole jurisdiction for the tapping of Utility mains and installation of wastewater service saddles and connections. All wastewater saddles, both new installations and upon replacement of a service line, shall be attached to the top of the main (Type I) as illustrated in Figure 12. Type II connections require Utility approval at the time of application. It is imperative that the installer verifies the wastewater main elevation and the wastewater service elevation/slope prior to the installation of the wastewater service piping.
- b) For connecting Type I services, provide a "long sweep" no-hub cast iron elbow fitting as shown in Figure 12. For D.I.P. services, provide two 45° mechanical joint fittings in series. The wastewater service line shall be run in practical alignment and at a uniform slope of not less than one-quarter (1/4") inch per foot toward the point of disposal. Where it is impractical, due to the depth of the street wastewater main or to structure features to obtain a slope of one-quarter (1/4") inch per foot, any such pipe four (4") inches or larger may have a slope of not less than one-eighth (1/8") inch per foot.
- c) The wastewater service line shall not be laid through any existing cesspool or septic tank unless such cesspool or septic tank has been excavated, backfilled, and compacted.
- d) Wastewater service line piping shall be laid on a firm bed of approved materials that have been properly compacted throughout its entire length.
- e) Wastewater service lines constructed of HDPE pipe must use pipe that is pre-insulated in a factory setting with a minimum of three (3") inches of urethane spray foam insulation. Insulation shall be rigid closed cell, two (2) component, urethane foam and be applied by an experienced applicator.
- f) Wastewater services that are insulated in the trench shall be laid to grade and blocked every five (5') feet so that there are no sags and the bottom of the pipe is at least three (3") inches above the bottom of the trench. This is necessary to ensure adequate insulation on the bottom of the service pipe.
- g) Fittings shall consist of the following:
  - No-Hub cast iron fittings for HDPE pipe (HDPE fittings are not allowed).
  - Ductile iron fittings for ductile iron pipe.
- h) Persons seeking approval of materials that are not specifically mentioned as being approved in this document must do so prior to installation.

- i) High-density polyethylene pipe shall be installed with gas tight and water tight, non-fusion joints. The connection of HDPE to HDPE pipe or HDPE pipe to a No-Hub fitting shall be a flexible coupling, such as Mission Rubber Company XL 56-44 ARC Flex-Seal Coupling for four (4") inch diameter piping. Any substitute must be approved by the Utility in writing, prior to installation. The Utility does not allow the use of standard no hub clamps from the building stub out to the wastewater main. Butt welding of HDPE pipe joints is not allowed. The Fernco Coupling 1056-44RCXL is an acceptable substitute. As an alternative, pipe connections may be made with an all stainless steel, full circle clamp coupling with neoprene gasket as a Rockwell No. 256, Romac style SS1.
- j) When connecting wastewater service pipe having different outside diameters, an all stainless steel, full circle clamp coupling as described above shall be used and the smaller outside diameter pipe shall be built up with three (3") inch wide neoprene gasket material to match inside diameter.
- k) When connecting a HDPE pipe to a woodstave saddle, a compression joint sealer shall be used such as a Fernco donut (490-405 for four (4") inch piping). When connecting a ductile iron pipe to a woodstave saddle, a compression joint sealer shall be used as a Fernco donut (490-111D for four (4") inch piping).

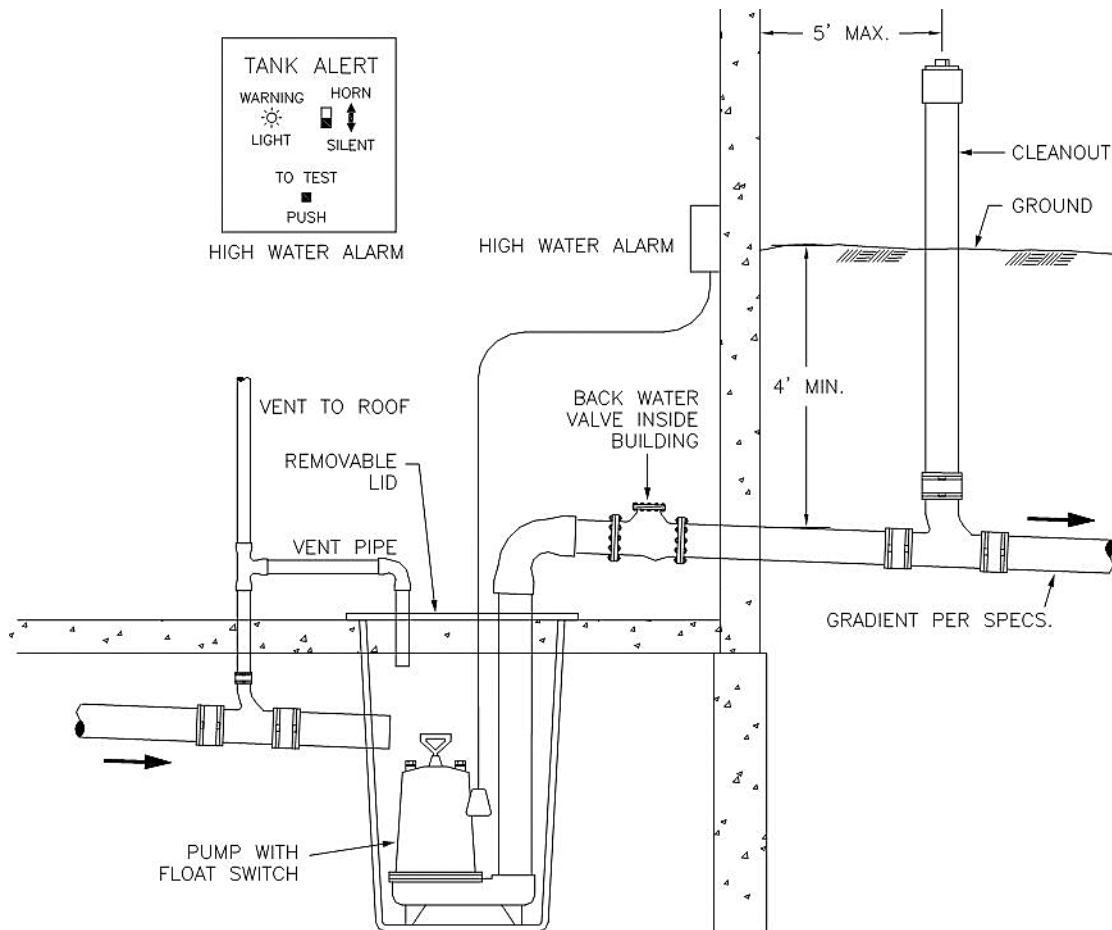
## 5.5 CLEANOUTS

- a) Wastewater clean-outs will be installed using a "No Hub" cast iron wye and one eighth (1/8) bend, or combination, and a vertical cast iron pipe riser with iron bodied clean out cap, not less than four (4") inch in diameter.
- b) A clean out shall be placed in every service line no farther than five (5') feet outside the building and at intervals not to exceed one hundred (100') feet, in straight runs.
- c) Changes in alignment or grade in excess of forty five (45) degrees in a building wastewater service line shall be served by a clean out.

## 5.6 BACKWATER VALVES

- a) The installer shall provide a backwater valve approved by the Utility (as shown in Figure 13) designed to prevent the flow of wastewater from Utility mains into the structure for that part of the wastewater service that is connected to fixtures with flood level rims located below the elevation of the nearest upstream manhole cover of the Utility wastewater system as required by Section 710 of the Uniform Plumbing Code.

- b) Backwater valves shall be located where they will be accessible for inspection and repair at all times, and unless continuously exposed shall be enclosed in a watertight pit, fitted with an adequately sized removable cover.

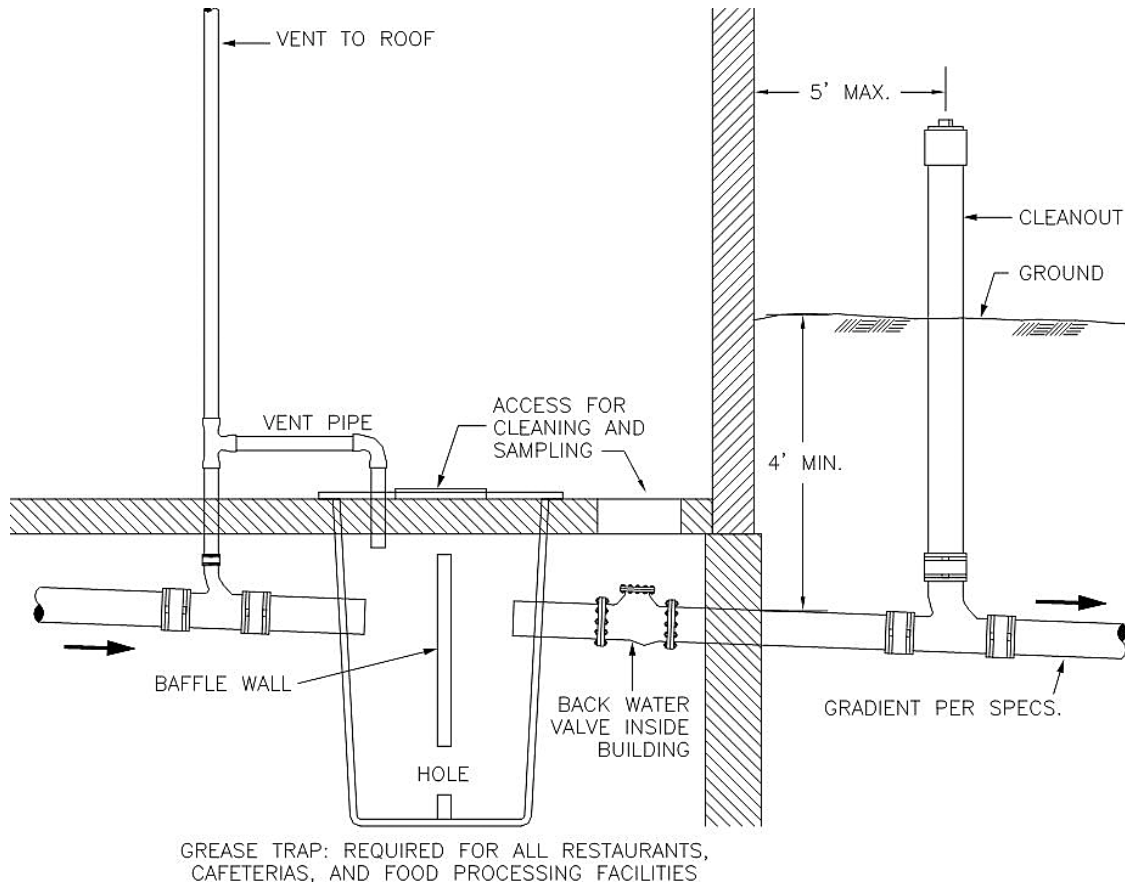


**Figure 13: Wastewater Service Lift Station**

## 5.7 LIFT STATIONS

- a) Occasionally, the location and distance of the facility to be served by the Utility is such that gravity drainage is not possible along the entire length of the wastewater service. The installer shall, at the direction of the Utility, install a suitable lift station to provide the necessary pumping capacity to meet the volume, elevation, and distance requirements of the wastewater service. Basic requirements and features of lift stations are as shown in Figure 13, and as described by the Uniform Plumbing Code.

- b) The lift station shall feature a tank, a suitable pump with motor starting control, a level switch, an access plate for maintenance of the tank, and alarm switch contacts for high water level.
- c) The installer shall furnish an alarm light and audible alarm to be activated on high water level switch closure.



**Figure 14: Typical Wastewater Interceptor Tank**

## 5.8 PRE-TREATMENT

The Utility has established a federally required Industrial Pre-treatment Program. All solid or liquid wastes which are prohibited, by ordinance or tariff, from being discharged into the Utility wastewater system shall be removed from the waste stream or pre-treated prior to final discharge. The type of pre-treatment device or system will be determined by the Utility.

- a) Grease Traps/Interceptors: The customer will furnish and maintain a grease trap/interceptor to trap animal and vegetable based greases and oils. Final acceptance of such a device is subject to approval by the Utility. All commercial kitchens and other food processing facilities shall be equipped with such a device. Further applicability and information on this requirement can be obtained from the Utility. See Figure 14.
  
- b) Sand Traps and Oil/Water Separators: The customer will furnish and maintain an approved sand trap designed to collect sand, dirt, silt and gravel from vehicle washing facilities or those facilities of similar purpose. As determined by the Utility, the customer will furnish and maintain an approved oil/water separator designed to collect petroleum or mineral based oils and greases. Those facilities requiring an oil/water separator include, but are not limited to, those performing vehicle maintenance and vehicle washing. Specific discharge limits and applicability of such pre-treatment devices shall be determined by the Utility.
  
- c) Disposal: The sludge, grease, oils, silt, grit or sand collected in the pre-treatment devices shall not be disposed in the wastewater main. The waste material must be disposed in a safe and acceptable manner in accordance with the Environmental Protection Agency and Alaska Department of Environmental Conservation regulations, or any other applicable regulations.